



**TZ-8XP**  
**系列/series**  
Strength Machine

**TZ-8101**  
推胸训练器  
Iso-Lateral Bench Press

Machine Weight:140kg  
Machine Size(L\*W\*H):1904\*1305\*1828mm



**TZ-8102**  
45°倒蹬训练器  
45 Degree Leg Press

Machine Weight:197kg  
Machine Size(L\*W\*H):  
2548\*1595\*1567mm



**TZ-8103**  
超上斜推胸训练器  
Iso-Lateral Super Incline Press

Machine Weight:137kg  
Machine Size(L\*W\*H):1728\*1294\*1478mm



**TZ-8104**  
分动式划艇低拉背训练器  
Iso-Lateral Low Row

Machine Weight:139kg  
Machine Size(L\*W\*H):1418\*1250\*1651mm



**TZ-8105**  
划船拉背训练器  
Iso-Lateral Bench D.Y.Row

Machine Weight:135kg  
Machine Size(L\*W\*H):1718\*1525\*2086mm



**TZ-8106**  
划船训练器  
Iso-Lateral Rowing

Machine Weight:128kg  
Machine Size(L\*W\*H):1512\*1372\*1305mm



**TZ-8107**  
坐式伸腿训练器  
Iso-Lateral Leg Extension

Machine Weight:126kg  
Machine Size(L\*W\*H):1775\*1549\*1443mm



**TZ-8108**  
高拉训练器  
Iso-Lateral Wide Pulldown

Machine Weight:143kg  
Machine Size(L\*W\*H):1649\*1288\*1657mm



**TZ-8109**  
顺蹬训练器  
Hack Squat

Machine Weight:168kg  
Machine Size(L\*W\*H):2094\*1644\*1260mm



**TZ-8110**  
阔角度推胸训练器  
Iso-Lateral Bench Wide Chest

Machine Weight:141kg  
Machine Size(L\*W\*H):2249\*1250\*1780mm



**TZ-8111**  
扭转组合训练器  
Combo Twist

Machine Weight:100kg  
Machine Size(L\*W\*H):1491\*1385\*1506mm



**TZ-8112**  
内高拉训练器  
Iso-Lateral Front Lat Pulldown

Machine Weight:145kg  
Machine Size(L\*W\*H):1776\*964\*2009mm



**TZ-8113**  
分动式推举训练器  
Iso-Lateral Shoulder Press

Machine Weight:139kg  
Machine Size(L\*W\*H):1779\*1363\*1740mm



**TZ-8114**  
下斜推胸训练器  
Chest Press

Machine Weight:141kg  
Machine Size(L\*W\*H):1850\*1397\*1736mm



**TZ-8115**  
腿后屈训练器  
Iso-Lateral Leg Curl

Machine Weight:128kg  
Machine Size(L\*W\*H):1584\*1499\*993mm



**TZ-8116**

**跨步下蹲训练器**  
**Squat Lunge**

Machine Weight:122kg  
Machine Size(L\*W\*H):1585\*1422\*850mm

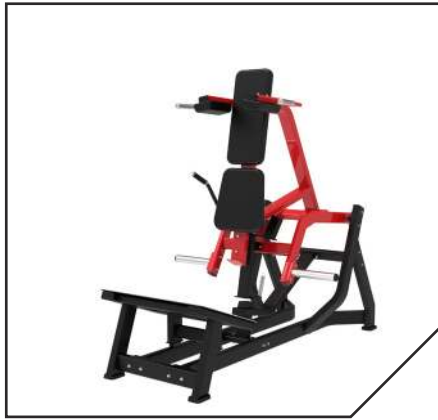

**TZ-8117**

**V型深蹲训练器**  
**V-Squat Rack**

Machine Weight:160kg  
Machine Size(L\*W\*H):2101\*1309\*1600mm



**TZ-8118**

**蹬腿训练器**  
**Leg Press**

Machine Weight:148kg  
Machine Size(L\*W\*H):1877\*1642\*1403mm

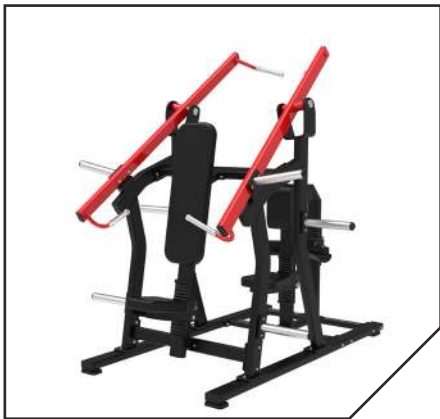

**TZ-8119**

**分动式推胸及高拉背训练器**  
**Iso-Lateral Chest/Back**

Machine Weight:160kg  
Machine Size(L\*W\*H):2210\*1693\*1713mm



**TZ-8121**

**仰卧推胸训练器**  
**Iso-Lateral Horizontal Press**

Machine Weight:112kg  
Machine Size(L\*W\*H):1579\*1527\*1017mm

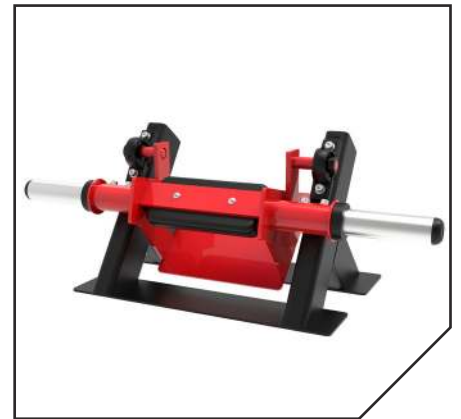

**TZ-8123**

**胫骨肌训练器**  
**Tibia Dorsi Flexion**

Machine Weight:28kg  
Machine Size(L\*W\*H):940\*403\*353mm



**TZ-8124**

**小臂训练器**  
**Wrist Curl Machine**

Machine Weight:36kg  
Machine Size(L\*W\*H):1044\*563\*465mm



**TZ-8125**

**卷腹训练器**  
**Abdominal Oblique Crunch**

Machine Weight:138kg  
Machine Size(L\*W\*H):1673\*1157\*1639mm



**TZ-8126**

腿外侧训练器  
**Abductor Machine**

Machine Weight:115.5kg  
Machine Size(L\*W\*H):1697\*826\*1303mm



**TZ-8127**

腿内侧训练器  
**Adductor Machine**

Machine Weight:115kg  
Machine Size(L\*W\*H):1436\*1383\*1303mm



**TZ-8128**

坐式下压三头肌训练器  
**Seated Dip**

Machine Weight:161kg  
Machine Size(L\*W\*H):1564\*1560\*1088mm



**TZ-8129**

坐式二头肌训练器  
**Seated Biceps**

Machine Weight:89kg  
Machine Size(L\*W\*H):1440\*1187\*949mm



**TZ-8130**

坐式提小腿训练器  
**Seated Calf Raise**

Machine Weight:55kg  
Machine Size(L\*W\*H):1260\*610\*925mm



**TZ-8131**

挂片式夹胸训练器  
**Pec Fly**

Machine Weight:72kg  
Machine Size(L\*W\*H):1437\*1346\*1085mm



**TZ-8132**

甩肩机  
**Lateral Shoulder Press (Plate Loaded)**

Machine Weight:76kg  
Machine Size(L\*W\*H):1334\*1164\*1551mm



**TZ-8133**

臀桥机  
**Hip Thrust Glute Machine**

Machine Weight:65kg  
Machine Size(L\*W\*H):1532\*1531\*888mm



**TZ-8134**

站姿飞鸟  
**Lateral Shoulder Press**

Weight Stack:80kg  
Machine Weight:150kg  
Machine Size(L\*W\*H):1061\*774\*1555mm



**TZ-8135**

掰手腕训练器  
Wrist Curl Machine

Weight Stack:50kg  
Machine Weight:83kg  
Machine Size(L\*W\*H):548\*518\*1112mm



**TZ-8136**

臀桥机  
Hip Thrust Glute Machine

Machine Weight:70kg  
Machine Size(L\*W\*H):1638\*1531\*888mm



**TZ-8137**

罗马椅  
ROMAN CHAIR

Machine Weight:57kg  
Machine Size(L\*W\*H):2090\*839\*1132mm

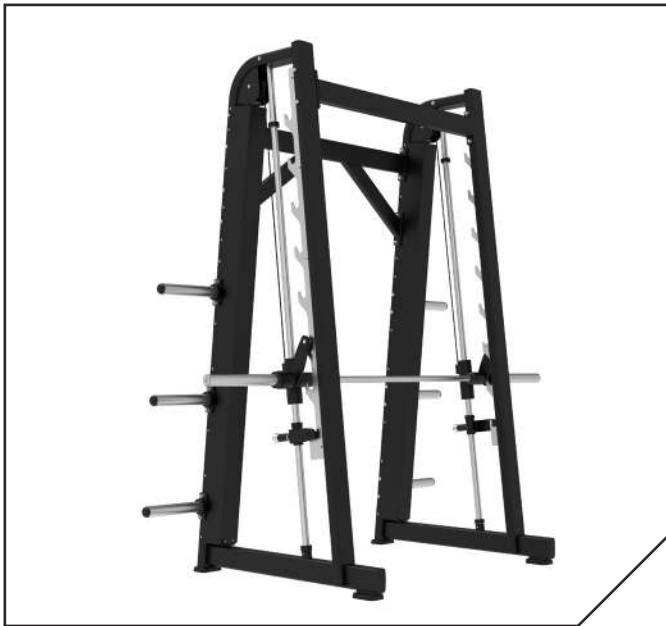

**TZ-8161**

史密斯  
Smith Machine

Machine Weight:179kg  
Machine Size(L\*W\*H):2342\*1142\*2395mm

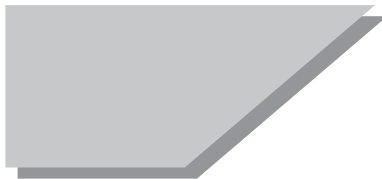
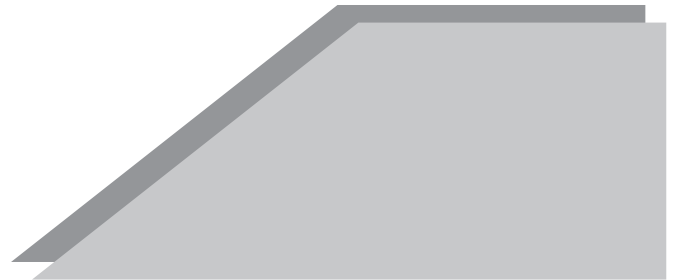

**TZ-8164**

垂直倒蹬机  
Vertical Leg Press

Machine Weight:124kg  
MachineSize(L\*W\*H):1724\*1720\*1821mm